

# RS2100

Ring Scanner



**ZEBRA**

## **Quick Start Guide**

2024/03/13

ZEBRA and the stylized Zebra head are trademarks of Zebra Technologies Corporation, registered in many jurisdictions worldwide. All other trademarks are the property of their respective owners. ©2023 Zebra Technologies Corporation and/or its affiliates. All rights reserved.

Information in this document is subject to change without notice. The software described in this document is furnished under a license agreement or nondisclosure agreement. The software may be used or copied only in accordance with the terms of those agreements.

For further information regarding legal and proprietary statements, please go to:

SOFTWARE: [zebra.com/linkoslegal](https://zebra.com/linkoslegal).

COPYRIGHTS: [zebra.com/copyright](https://zebra.com/copyright).

PATENTS: [ip.zebra.com](https://ip.zebra.com).

WARRANTY: [zebra.com/warranty](https://zebra.com/warranty).

END USER LICENSE AGREEMENT: [zebra.com/eula](https://zebra.com/eula).

## Terms of Use

### Proprietary Statement

This manual contains proprietary information of Zebra Technologies Corporation and its subsidiaries ("Zebra Technologies"). It is intended solely for the information and use of parties operating and maintaining the equipment described herein. Such proprietary information may not be used, reproduced, or disclosed to any other parties for any other purpose without the express, written permission of Zebra Technologies.

### Product Improvements

Continuous improvement of products is a policy of Zebra Technologies. All specifications and designs are subject to change without notice.

### Liability Disclaimer

Zebra Technologies takes steps to ensure that its published Engineering specifications and manuals are correct; however, errors do occur. Zebra Technologies reserves the right to correct any such errors and disclaims liability resulting therefrom.

### Limitation of Liability

In no event shall Zebra Technologies or anyone else involved in the creation, production, or delivery of the accompanying product (including hardware and software) be liable for any damages whatsoever (including, without limitation, consequential damages including loss of business profits, business interruption, or loss of business information) arising out of the use of, the results of use of, or inability to use such product, even if Zebra Technologies has been advised of the possibility of such damages. Some jurisdictions do not allow the exclusion or limitation of incidental or consequential damages, so the above limitation or exclusion may not apply to you.

# Unpacking

Carefully remove all protective material from the scanner and save the shipping container for later storage and shipping.

Verify that the box contains the equipment listed below:

- RS2100
- Regulatory Guide

Inspect the equipment for any damage. If you are missing any equipment or if you find any damaged equipment, contact Support immediately.



**ATTENTION:** the RS2100 ships in Ship Mode. This is a low-power that protects the battery. Press the scan trigger or charge the scanner to exit Ship Mode.

# Features

This section lists the features of the RS2100.

**Figure 1** Side View

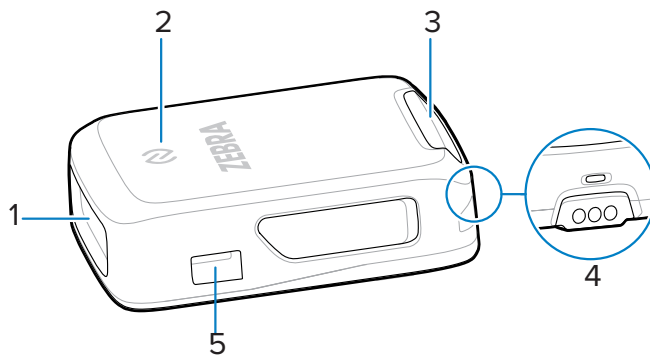

Item	Description
1	Imager window
2	NFC icon
3	Notification LED
4	IO contacts
5	Tab notch

**Figure 2** Slim Mount Mounted Side View

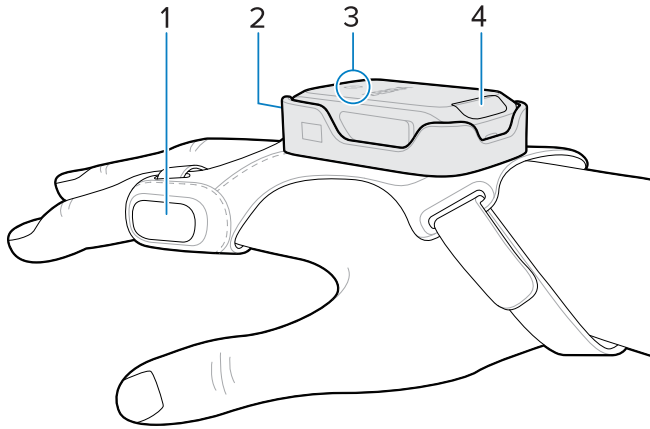

Item	Description
1	Scan trigger
2	Imager window
3	NFC icon
4	Notification LED

# Status Indications

The RS2100 notification LED on the back of the device indicates Bluetooth, battery, and decode status. The beeper emits beep sequences and patterns to indicate status.

The following table defines the notification LED and beep sequence status indications.

Category	LED Indication	Beep Indication	Description
Power Indication	Green	Low/medium/high	Device is powered on.
Scanning Indications	Green single flash	High	Successful barcode decode.
	Red	4x low	Transmission error.
	Red	5x low	Conversion or format error.
	Red	Low/high/low/high	Out of batch memory storage. Unable to store a new barcode.
Radio Indications	Red/Green blinking	6x short high	Device in paging state.
	Blue double blink	High/low	Bluetooth communication is disconnected.
	Blue slow blinking	None	Attempting to reconnect over Bluetooth.
	None	Low/high	Bluetooth connection established.
	None	Long low/long high	Bluetooth connection attempt failed.
	Blue during beep sequence	Long low/long high/ long low/long high	Bluetooth connection attempt rejected.
	Blue slow blinking	5x high	Attempting to reconnect over Bluetooth (disabled by default).
	Blue blinking	3x high	Bluetooth disconnect indication (disabled by default).
Battery Indications	Red	4x high	Battery charge is low.
	Green/Amber/Red	N/A	Battery charge level indication (hold trigger for three seconds to activate). <ul style="list-style-type: none"> <li>• Green &gt; 40%</li> <li>• Amber 10% - 39%</li> <li>• Red &lt; 9%</li> </ul>
Charging Indications	Amber	N/A	Scanner is charging. Battery level is 0% - 98%.

## Status Indications

Category	LED Indication	Beep Indication	Description
	Green	N/A	Scanner is charged. Battery level is 98% - 100%.
	Red flash, then no illumination	N/A	Scanner temperature is too high. Charging is paused until scanner temperature decreases <sup>a</sup> .
Parameter Programming	Red	Long low/long high	Input error, incorrect barcode or <b>Cancel</b> scanned, wrong entry, incorrect barcode programming sequence; remain in program mode.
	Green	High/low/high/low	Successful program exit with change in the parameter setting.
Maintenance Indications	Green slow blinking	N/A	Scanner connected to 123Scan.
	Red fast blinking	N/A	A file is transferring to the scanner (new configuration parameters or firmware) via 123Scan.
	Red slow blinking	N/A	Firmware installation.
	Green	N/A	Programming completed successfully (parameter changes or firmware updated) via 123Scan.

<sup>a</sup> Charging resumes automatically when scanner temperature reaches acceptable levels.

# Mounting the Scanner

Mount the scanner onto the .

1. Push the LED-end of the scanner into the plastic slot.
2. Press the front end of the scanner into the slot. Push down firmly until the tabs close around the scanner's tab notches.

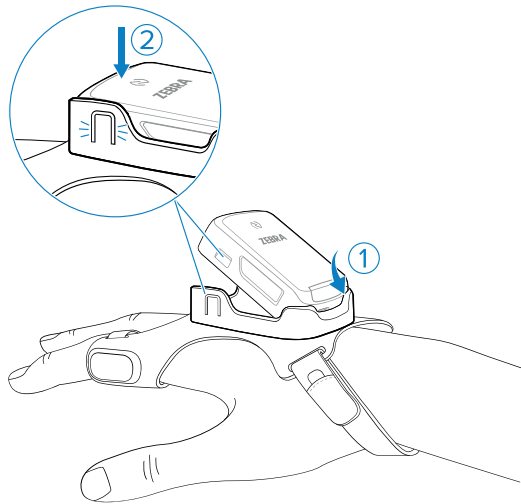

The scanner is ready for use.



**NOTE:** For new scanners:

Charge the scanner or press the scan trigger to exit low-power mode.

See [2-Slot Charger](#) for charging instructions.



# Placing the Slim Mount on Your Hand

Use the to mount the RS2100 onto your hand.

1. Loosen the finger strap (1) and wrist strap (2).

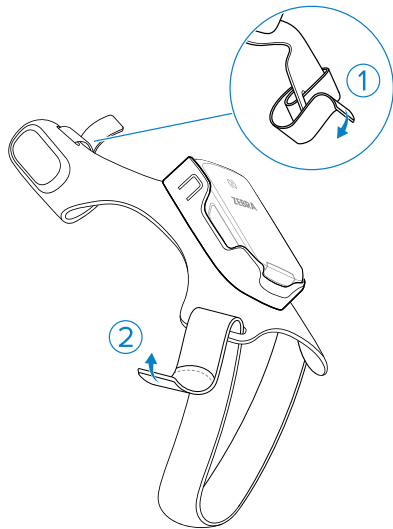

2. Slide your hand through the wrist strap and your index finger through the finger strap.

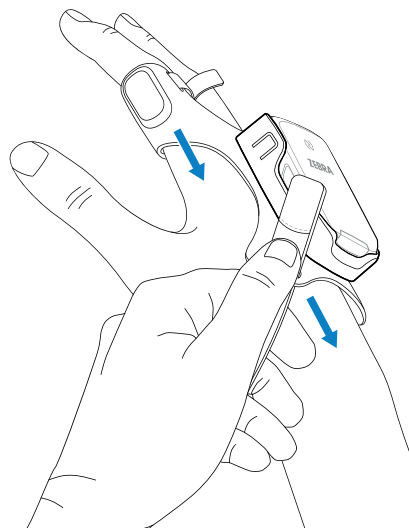

## Placing the Slim Mount on Your Hand

3. Pull the mount onto your hand until the wrist strap sits comfortably on your wrist and the finger strap is at the base of your finger.

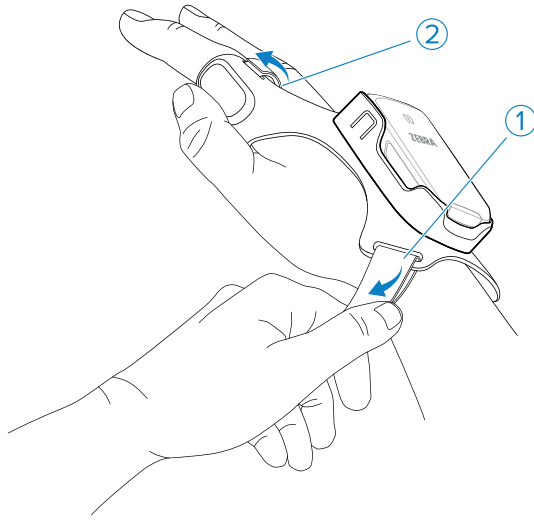

4. Secure the wrist strap and finger strap.

# Bluetooth Connection

The RS2100 sends decoded barcode data to Zebra mobile computers and other devices using Bluetooth.

To connect the RS2100 to a device via Bluetooth, see [Radio Communications](#).

Connecting to a host device consists of two distinct processes.

1. **Pairing:** The scanner pairs with the device, exchanging security information. Pairing information is stored in the scanner's memory, and the two devices are associated with one another.
2. **Connecting:** The scanner connects to the device. Connection allows the devices to communicate and send data back and forth.

A scanner may disconnect from the host device for a variety of reasons. A disconnected scanner is still paired with the device. You can manually scan/tap to reconnect the scanner to the paired device.

## Pairing using NFC Tap-to-Pair

The RS2100 is NFC-enabled and supports Bluetooth Tap-to-Pair.



**NOTE:** Not all Zebra devices support NFC readers and the Tap-to-Pair feature.

To connect with an NFC-enabled Zebra device:

1. Ensure NFC is enabled on the device.  
Refer to the product's Product Reference Guide to enable NFC.
2. Align the NFC icon on the RS2100 with the NFC icon on the device.

The Notification LED blinks blue, indicating that the RS2100 is attempting to establish a connection with the device. When a connection is established, the Notification LED turns off, and the RS2100 emits a single string of low/high beeps.

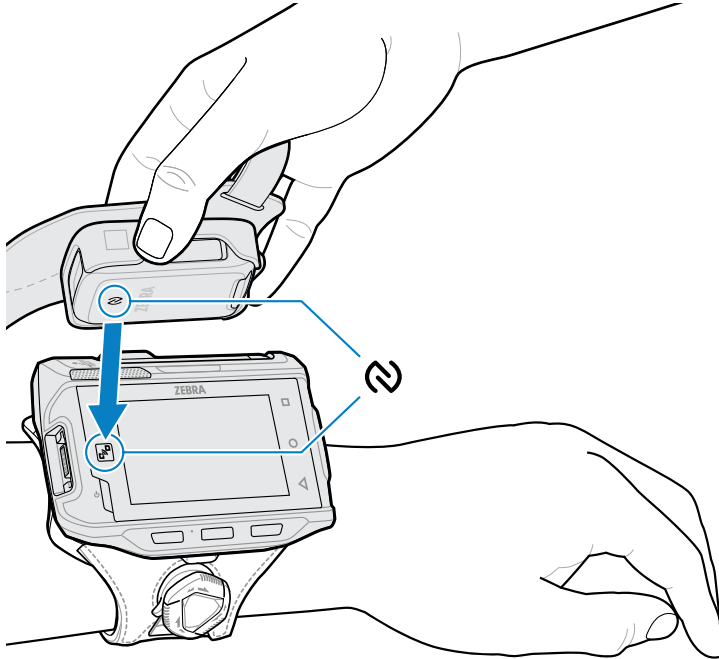

## Pairing With a Zebra Mobile Device

The RS2100 supports SSI Bluetooth pairing. Pair with a Bluetooth-enabled Zebra mobile device to send scan data or configure the scanner.

1. On the device, open **Settings > Bluetooth Pairing Utility**.

The **Bluetooth Pairing Utility** opens.

2. Using the RS2100, scan the barcode on the screen.

The Status LED blinks blue, indicating that the RS2100 is attempting to establish a connection with the device. When a connection is established, the Status LED turns off, and the RS2100 emits a single string of low/high beeps. The device indicates a successful pairing attempt with a toast notification (audio and visual). When the Bluetooth connection is established, dialog box notifications display on the device's screen.

3. On the device, return to the main screen.

## Pairing with a Consumer Bluetooth Device

The RS2100 supports HID Bluetooth pairing. Pair with a Bluetooth-enabled consumer device to send scan data or configure the scanner.

1. Use the RS2100 Product Reference Guide to enable the HID Bluetooth profile on the scanner.
2. Open your mobile device's settings.
3. Navigate to the Bluetooth pairing page.
4. Select RS2100 XXXXXXXX, where XXXXXXXX corresponds to the scanner's ID.

The Notification LED blinks blue, indicating that the RS2100 is attempting to establish a connection with the device. When a connection is established, the Notification LED turns off, and the RS2100 emits a single string of low/high beeps.

## Pairing With a Bluetooth Adapter

The RS2100 Bluetooth profile supports Scan-to-Pair. Scan the pairing code to pair with the Bluetooth Adapter (BT-RS5X6-DNGL-01).

1. Ensure the scanner is in factory default mode. Scan the factory default barcode to return the scanner to its factory default settings.



2. Using the RS2100, scan the pairing code (1) on the adapter.

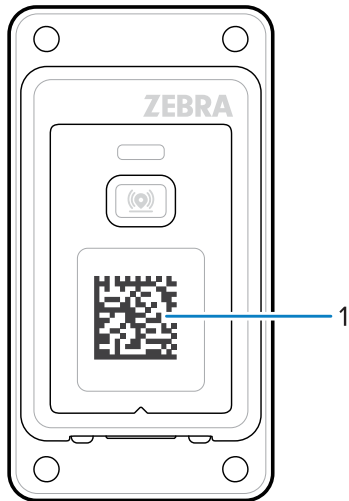

The Status LED blinks blue, indicating that the RS2100 is attempting to establish a connection with the device. When a connection is established, the Status LED turns off, and the RS2100 emits a single string of low/high beeps.

# Scanning a Barcode

The RS2100 uses a digital camera to take an image of a barcode, and software algorithms extract the barcode data from the image.

1. Aim the Imager Window at the barcode and press the scan trigger on the Slim Mount.



**NOTE:** Imager decoding usually occurs instantaneously. When the device is in Picklist mode, the scanner does not decode the barcode until the red crosshair touches the barcode.

2. Ensure the barcode is within the area formed in the aiming pattern.

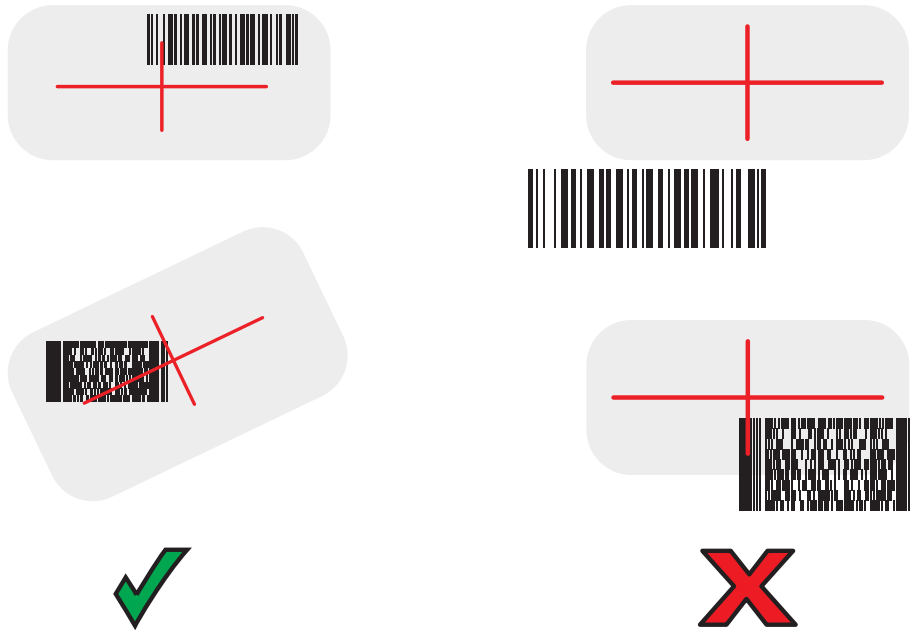

The Status LED illuminates red. Upon successful decoding, the Status LED changes from red to green, and an audible beep sounds.

# Charging

Use the 2-slot charger to charge the RS2100.



**NOTE:** This charger does not provide communication functionality.



**NOTE:** Follow the guidelines for battery safety described in the RS2100 Product Reference Guide.



**IMPORTANT:** The scanner ships in a battery-saving mode. To exit battery-saving mode and enable scanning, insert the scanner into the charger.

## 2-Slot Charger

The 2-Slot Charger charges up to two scanners.

**Figure 3** 2-Slot Charger Setup

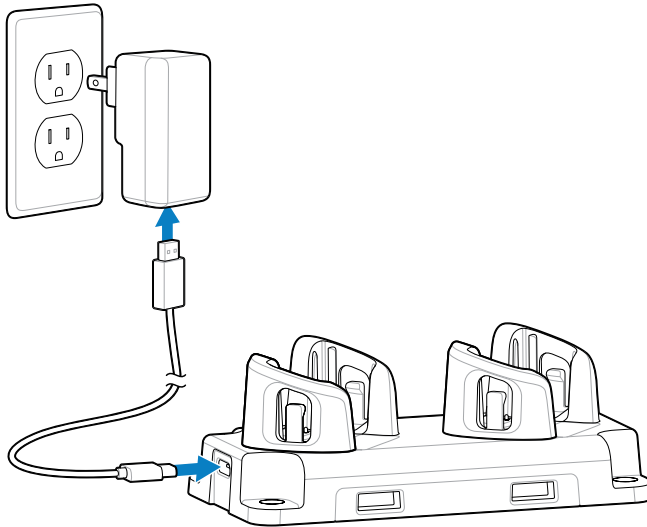

## Battery Charging

The RS2100 LED indicates scanner battery charging status.

State	Indication
Off	The scanner is not charging. The RS2100 is incorrectly inserted. Charger is not powered. Check the power cable and the power supply.
Solid Amber	Scanner is charging.
Solid Green	Scanner charging is complete.
Fast Blinking Red (2 blinks/second)	Charging error, such as: <ul style="list-style-type: none"> <li>Battery temperature is too low or too high for charging.</li> <li>The battery has reached the charge cycle time-out period. Battery charging has gone on too long without completing a full charge cycle (typically eight hours).</li> </ul>

Charge batteries in temperatures from 5°C to 40°C (41°F to 105°F). The standard battery charges from 0% to 90% in less than two and a half hours at room temperature. When the charging temperature is between 5°C to 10°C (41°F to 50°F), the standard battery charges in less than five hours.

The device and charger monitor battery temperature. Battery charging is only performed when the battery is within safe charging temperature limits. At higher temperatures (at approximately +35 °C (+95 °F) the device or charger may, for small periods of time, alternately enable and disable battery charging to keep the battery at acceptable temperatures. This process may increase charging time. The RS2100 indicates when charging is disabled due to abnormal temperatures via the Status LED.



# Scanner Storage

The RS2100's battery drains while it is stored and not in use. For long-term storage, enable low-power mode.

Low-power mode preserves the scanner battery and prevents the scanner from entering an unrecoverably low battery level. Scan this barcode to enter low-power mode.

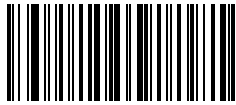

Charge the scanner or press the scan trigger to exit low-power mode.

# Ergonomic Considerations

The scanner allows the user to enjoy the following benefits:

- Improve work procedures
- Keep objects that are used frequently within easy reach
- Maintain a natural position
- Perform tasks at correct heights
- Provide adequate clearance
- Provide a suitable working environment
- Reduce or eliminate direct pressure
- Reduce or eliminate excessive force
- Reduce or eliminate repetitive motion
- Reduce or eliminate vibration

