

Automatic labeller for medium and high speed applications.



Available with max. label width: 140 mm - 250 mm - 350 mm.

- Max. speed: **up to m/min: 50(140) - 35(250) - 25(350)**
- Max. label width: **350 mm**
- Roll diameter: **300 mm**
- Approx dimensions: **900 x 600 x 350 mm**

EN

## STANDARD FEATURES

Hybrid step-motor low-loss A++ Class  
Mechanical un-winder  
Stop photocell  
End of roll alarm  
Encoder in-put  
Touch Screen operator panel  
Offset and start delay adjustment  
Automatic recovery of missing label  
Applied label counter  
Setting memorization

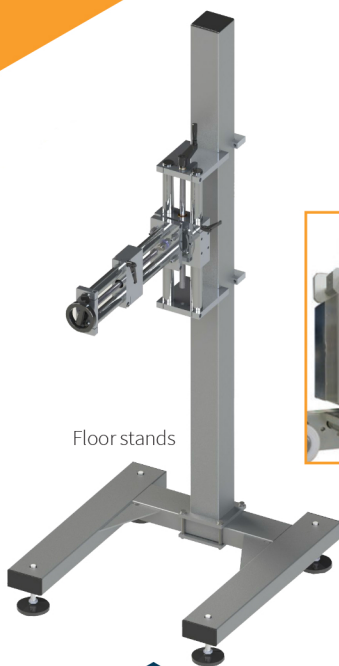

Floor stands



Thermal transfer printers



## APPLICATIONS AREAS



## OPTIONAL ACCESSORIES

Pre-end of labels roll alarm  
Photo-stop for transparent labels  
Start photocell  
Oscillating roller applicator  
Pneumatic applicators  
Hot foil coding unit  
Thermal transfer printing units